

CUSTOMER SPECIFICATION SHEET - SHOWERS

SALES CODE: CSB120

DESCRIPTION: Victrion Superbe Rigid Riser Kit

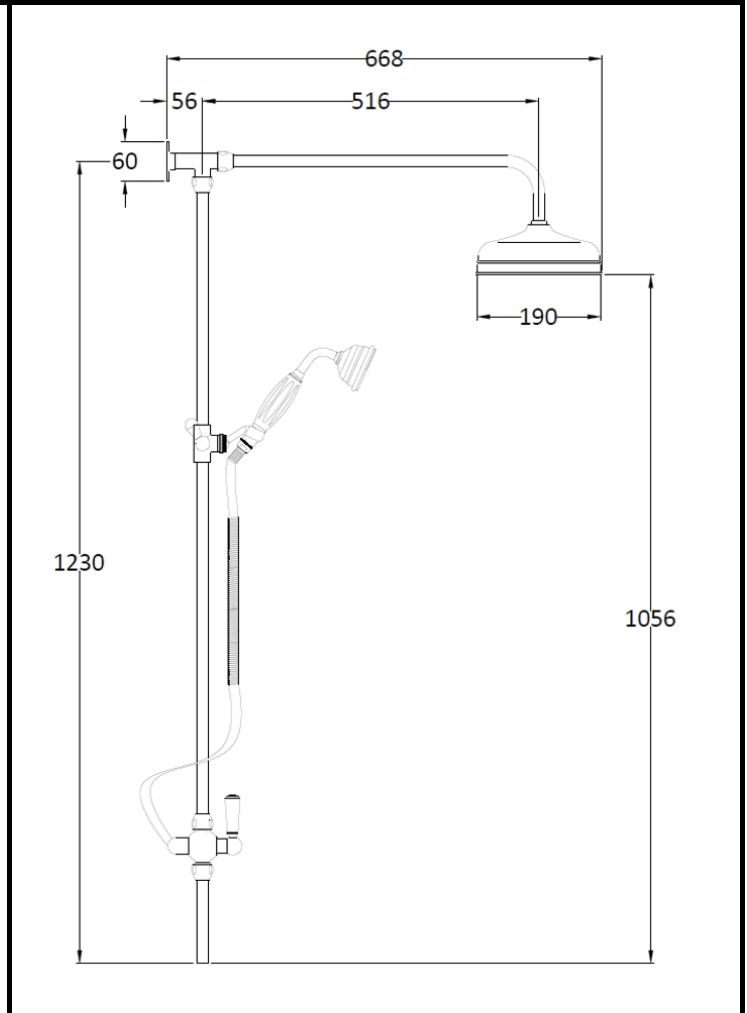

PRODUCT DIMENSIONS

Length(mm)	Width (mm)	Height (mm)	Depth (mm)	Nett Wgt Kg
	194	1260	670	4.7

PACKAGING DIMENSIONS

Length (mm)	Width (mm)	Depth (mm)	Gross Wgt Kg
1100	240	110	5.2

PACKAGING DATA

Box Colour	White Cardboard Box		
Box Qty	1	Label Colour	White Label
Label Size	100 X 50	Label Qty	2

OUTER BOX DIMENSIONS (If Applicable)

Length (mm)	Width (mm)	Height (mm)	Depth (mm)	Gross Wgt Kg
Barcode				

PRODUCT DETAILS

Country of Origin	China
Fitting Instruction	No
Product Material	Brass
Mount Type	Surface, Wall
Outlet Elbow Supplied	No
Easy Clean	No
Head Included	Yes
Handset Included	Yes
Body Jets Included	No
No of Body Jets	Not Applicable
Operating Pressure (bar)	0.5
Valve/Cartridge Type	Not Applicable

Flow Rates (L/min)	0.1 bar	N/A	0.5 bar	N/A	1 bar	N/A	2 bar	N/A	3 bar	N/A
TMV2 Approved	No		Approval No.		N/A					
TMV3 Approved	No		Approval No.		N/A					
WRAS Approved	No		Approval No.		N/A					
Head Function	Single									
Handset Function	Single Setting									
Body Jet Info	Not Applicable									
Pipe Size	18 mm									
Pipe Centres	N/A									
Colour/Finish	Chrome									
Hose Included	Yes									